

Proper Input Network Selection Achieves Optimum Dynamic Performance and Excellent Gain Flatness in High-Speed ADCs

The following application note provides guidelines to select the appropriate transformer and passive components and achieve gain flatness over a wide range of input frequencies without sacrificing the dynamic performance of a high-speed data converter.

Proper selection of board components is an essential factor to meet the demanding high dynamic performance and gain flatness requirements in high-IF analog-to-digital converters (ADCs). The following technical note will lend some insight into the appropriate selection of input networks designed for easy single-ended to differential input signal conversion with the help of a wide-band transformer, termination resistors and filter capacitors.

The MAX1449 was chosen to demonstrate and analyze two possible input configuration designs. Figure 1 shows a typical AC-coupled, single-ended to differential conversion design using a wide-band transformer such as Mini-Circuit's T1-1T-KK81 (200MHz) with 50 Ω primary-side termination and a 25 Ω /22pF filter network. In this configuration, a single-ended signal from a 50 Ω -impedance source is taken and converted to a differential signal through the transformer. Primary-side termination into 50 Ω allows for excellent matching between the signal source and the transformer. However this also means that there is a mismatch between the primary and the secondary side of the transformer. The primary side looks into a combined impedance of 25 Ω , while the secondary side experiences a large impedance mismatch with the 20k Ω input resistance of the ADC shunted by 22pF. This will impact the frequency response of the input network, ultimately affecting the frequency response of the converter. The transformer's nominal leakage inductance can range anywhere from 25nH to 100nH. Combined with the input filter capacitor of 22pF this will create a disturbing resonance frequency:

$$f_0 = \frac{1}{2\pi \sqrt{L_{\text{XFORMER}} \cdot C_{\text{IN}}}}$$

located between 110MHz and 215MHz resulting in undesired gain peaking in this frequency range.

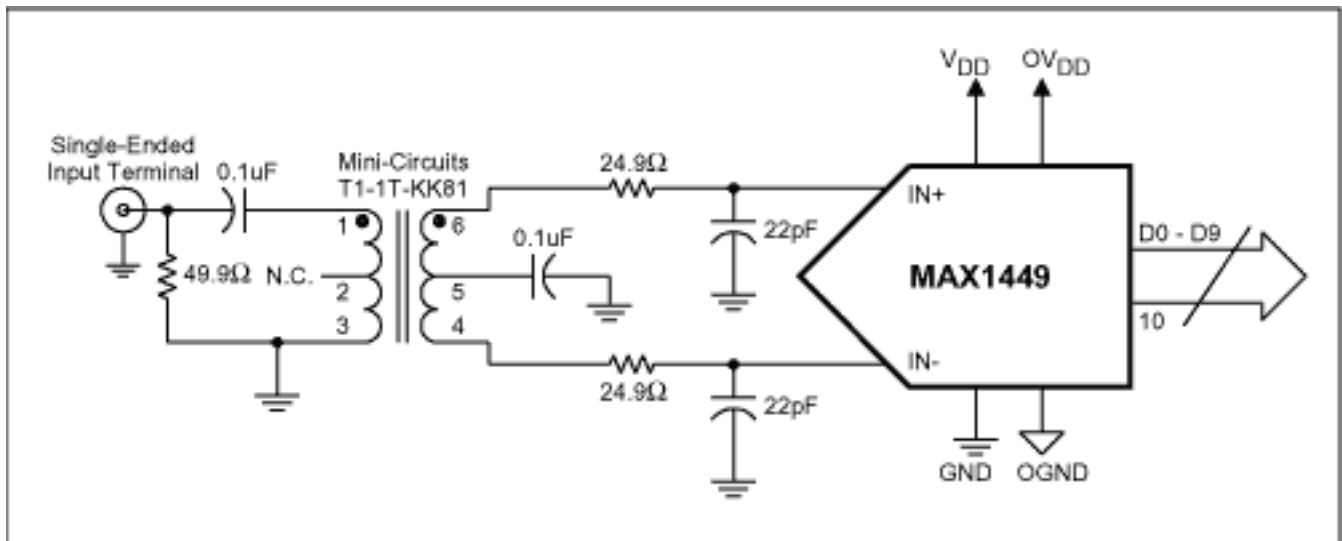

Figure 1.

Figure 2 depicts a similar AC-coupled configuration, however this circuit was designed with a better performing wide-band transformer such as Mini-Circuits ADT1-1WT (800MHz) with a primary-side termination and a $25\Omega/10\text{pF}$ filter network. Although, the ADT1-1WT is a 75Ω -impedance, its lower leakage inductance yields a significantly better frequency response of -1dB up to 400MHz, compared to only 50MHz for the T1-1T-KK81.

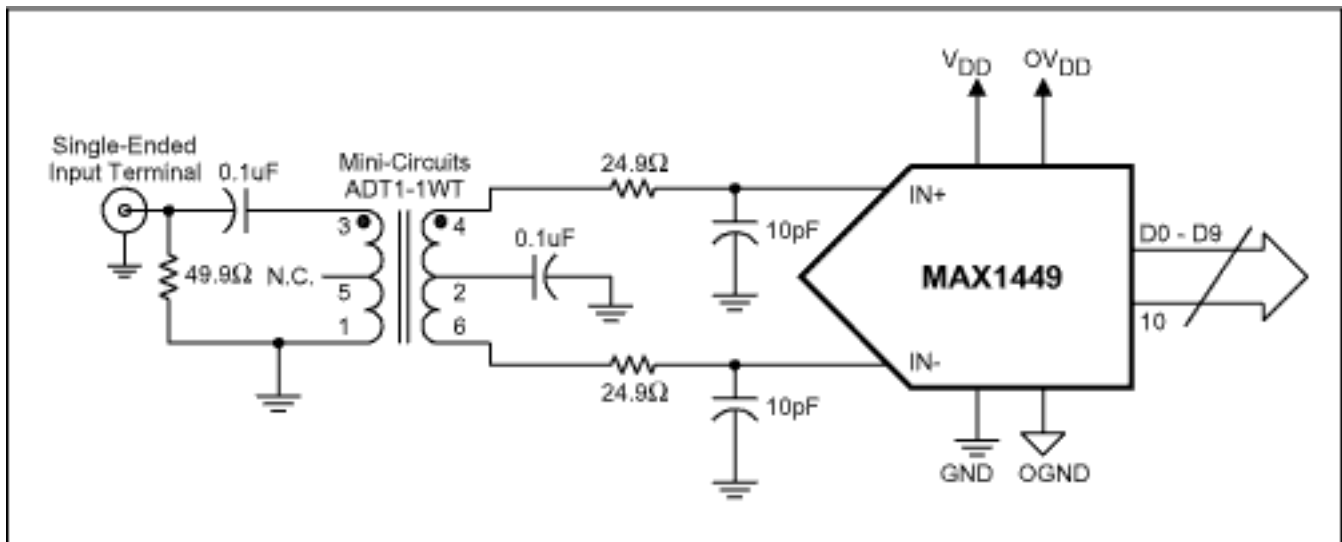

Figure 2.

Figure 3 shows the results for both termination schemes and selections of filter network components and transformers. A significant improvement can be observed between the two graphs. The input bandwidth trace for the T1-1T-KK81 transformer (blue) clearly shows a gain peaking of about 0.5dB between 90MHz and 110MHz, while the curve for the ADT1-1WT transformer (magenta) stays flat within a tenth of a dB for frequencies up to 300MHz. The dynamic performance for this condition (ADT1-1WT transformer, 50Ω

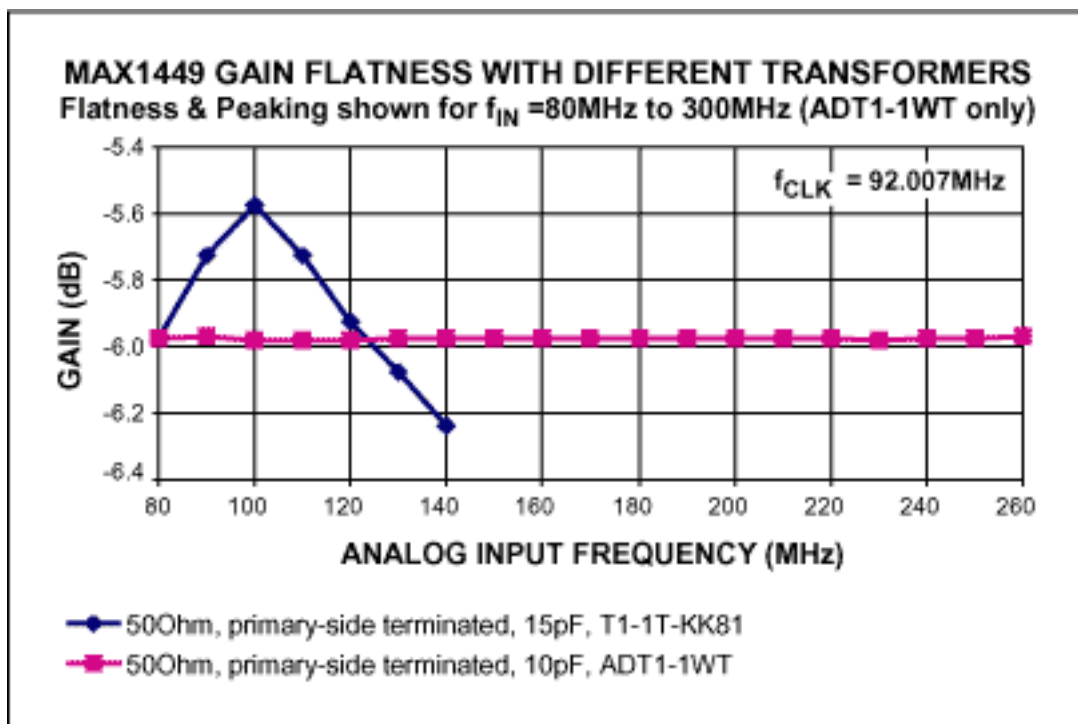

Figure 3.

primary-side termination and 10pF input filter capacitors at INP and INN) still yielded an excellent SNR of 58.4dB for $f_{IN}=50\text{MHz}$. Though Figure 3 only displays tested input frequencies of 80MHz and 260MHz (ADT1-1WT only), lab tests have proven that the gain remains flat within 0.1dB to input frequencies well beyond the 8th Nyquist region.

Taking an effort to better match the secondary side impedance of the transformer can help to further enhance the gain flatness. One way to do this is using a secondary-side termination rather than a primary-side termination. This approach will be covered in a separate application note based on some input network designs and their analysis performed with Maxim's recently introduced MAX1122/23/24 family. Refer to the application note link in the reference section (below) for further details on primary-side vs. secondary-side termination.

REFERENCES

MAX1448EVKit Datasheet, Rev1, 7/2001, Maxim Integrated Products, Sunnyvale, CA

MAX1449 Datasheet, Rev0, 10/2000, Maxim Integrated Product, Sunnyvale, CA

Application Note: [Secondary-Side Transformer Termination Improves Gain Flatness in High-Speed ADC](#)

More Information

MAX1449: [QuickView](#) -- [Full \(PDF\) Data Sheet](#) -- [Free Samples](#)

